

HANDLING • AUTOMATION

KEY2 MOTION

KEY2 Motion is the intelligent CYTEC control system which is future-proof optimally at this stage

- Safety system for all MotionPicker and MotionLiner.
- Ergonomic manual control unit with big 8,4" touch screen for quick and safe handling.
- Self-explanatory graphic KEYS make programming via process chaining easy and clear.



PERFORMANCE DATA	
Display	8,4" TFT colour display 800 x 600 pixels
Control panel	Touch screen Emergency switch Approval switch
Interfaces	1x USB Type A 2.0 1x Ethernet 1x VARAN-Bus 1x safety interface (safety specific)
Internal program and data storage (DDR3-RAM)	256 MByte
Internal remanent data storage	128 kByte MRAM
Internal storage device	MicroSD card
Weight	0,95 kg without connection cable
Dimensions	217,4 x 187,7 x 72 mm (W x H x D) (without emergency stop switch/key switch)
Ambient temperature range	0 up to +50 °C
Max. admissible ambient humidity	10-90 %, non-condensing
Protection class	EN 60529 / IP54

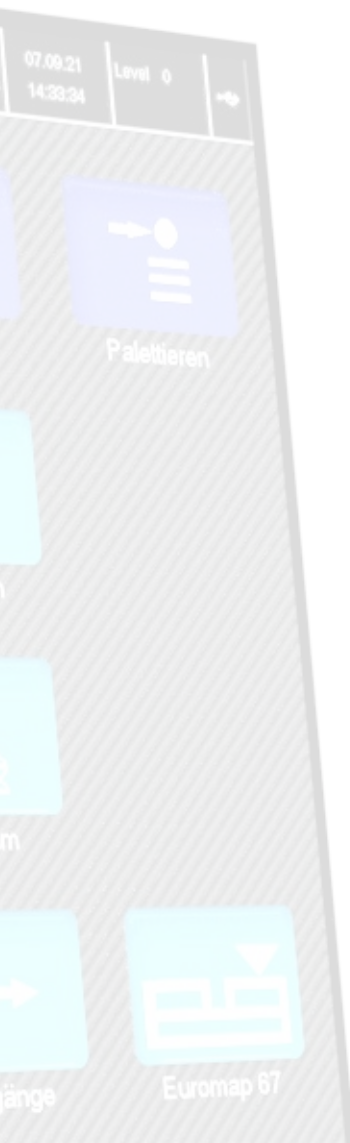

- proven **modular system**
- intuitively programmable **controller**
- highly dynamic **servo drive technology**
- precisely matched **expansion options**
- sprue removal, part insertion, stacking or palletizing
- load capacity **1,5 kg or 3,0 kg**
- use on injection moulding machines, autom. processing machines, assembly applications

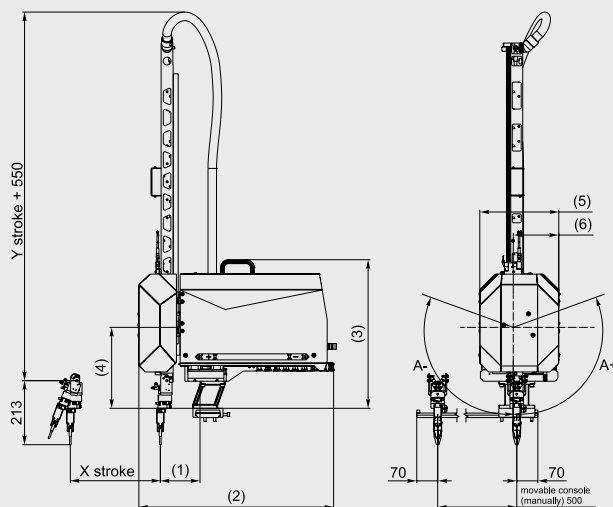

MOTION PICKER

X1	300; 400
Y1	1195 (Y 800); (Y 500 - Y 1000)
A+	105°
A-	-105°
(1)	137,2
(2)	703
(3)	509
(4)	391,3
(5)	265
(6)	159

Dimensions in mm

MOTION PICKER 1.5

- freely programmable control
- 1 Compressed air circuit

Axes X/Y/Z	AC-servo motor
Repeatability	±0,1 mm
Part, gripper and additional axis weights together	1,5 kg
For inj. moulding machines up to	3000 kN
Connected load	110/230 V (60/50)
Comp. air connection	6 bar
Comp. air consumption	appr. 0,3 NI/cycle (without vacuum)
Interface	Euromap 67



MOTION PICKER 3.0

- freely programmable control
- 1 Compressed air circuit

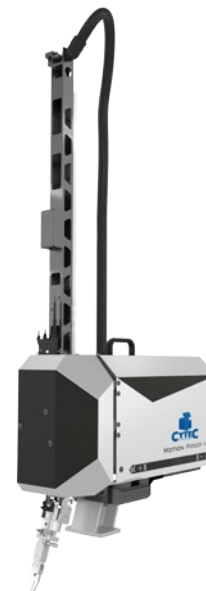

Axes X/Y/Z:	AC-servo motor
Repeatability	±0,1 mm
Part, gripper and additional axis weights together	3,0 kg
For inj. moulding machines up to	3000 kN
Connected load	110/230 V (60/50)
Comp. air connection	6 bar
Comp. air consumption	appr. 0,3 NI/cycle (without vacuum)
Interface	Euromap 67

MOTION LINER 5.0 | 10.0 | 20.0

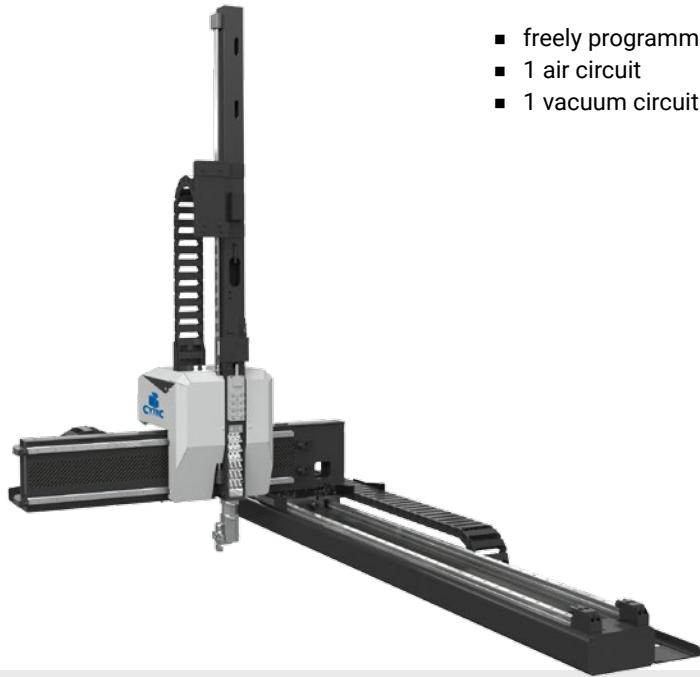

- freely programmable control
- 1 air circuit
- 1 vacuum circuit

- proven **modular system**
- intuitively programmable **controller**
- highly dynamic **servo drive technology**
- precisely matched **expansion options**
- sprue removal, part insertion, stacking or palletizing
- load capacity **5.0, 10.0 or 20.0 kg**
- use on injection moulding machines, autom. processing machines, assembly applications

5.0 (max. 5 kg) | **10.0** (max. 10 kg) | **20.0** (max. 20 kg)

Axes X/Y	AC-linear motor
Axis Y	AC-servo motor
Repeatability	±0,1 mm
Part, gripper and additional weight together	5/10/20 kg
Connected load	400 - 480 V (60/50 Hz)
Comp. air connection	6 bar
Interface	Euromap 67

OPTIONS

- version **Dual-Y**
- version **180°**
- version **360°**

	5.0, 10.0	20.0
X stroke	600; 800	
X stroke	800 - 1600	
Z stroke	1600 - 4300	
(1)	361	383
(2)	182	217
(3)	325	403
(4)	559	592
(5)	435	501
(6)	119	159
(7)	554	660

Dimensions in mm

APPLICATION

- extremely rigid design
- part insertion/extraction
- fast and precise

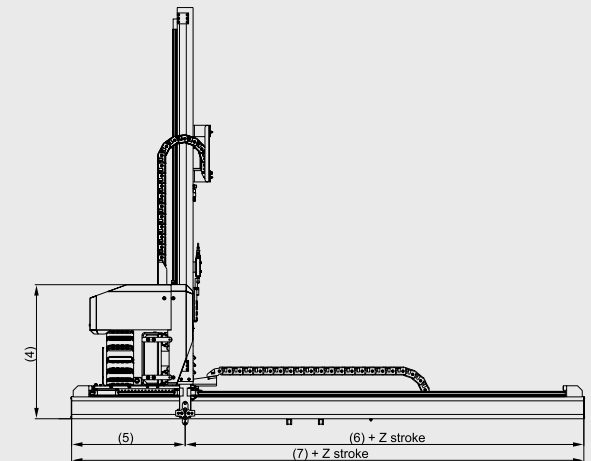
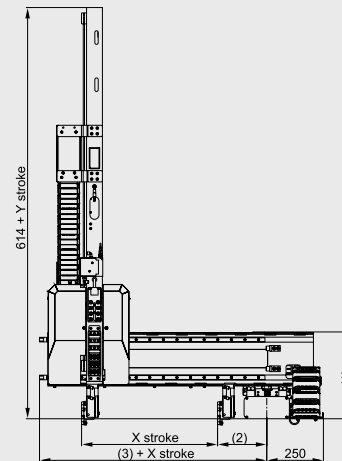

Picture: MotionLiner 20.0

MOTION LINER 5.0 XD | 10.0 XD | 20.0 XD



- freely programmable control
- 1 air circuit
- 1 vacuum circuit

5.0 (max. 5 kg) | 10.0 (max. 10 kg) | 20.0 (max. 20 kg)

Axes X/Y	AC-linear motor
Axis Y	AC-servo motor
Repeatability	±0,1 mm
Part, gripper and additional weight together	5/10/15/20 kg
Connected load	400 - 480 V (60/50 Hz)
Comp. air connection	6 bar
Interface	Euromap 67

OPTIONS

- Multi Head

	5.0, 10.0	20.0
X stroke	600; 800	
X stroke	800 - 1600	
Z stroke	1600 - 4300	
(1)	496	496
(2)	277	296
(3)	356	361
(4)	263	263
(5)	411	421
(6)	239	239
(7)	660	660

Dimensions in mm

APPLICATION

- high dynamic X-axis
- 2 component applications
- tools with high core puller
- machine intrusion from above

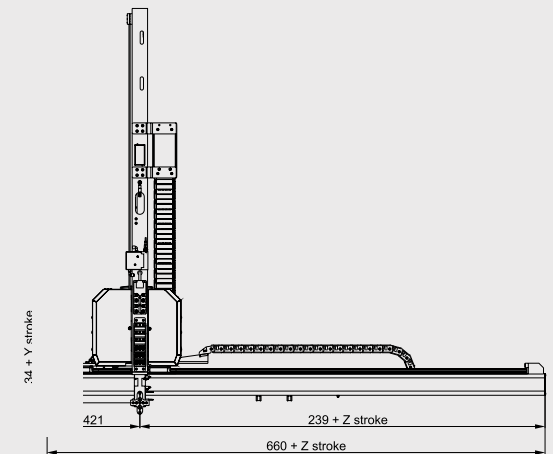
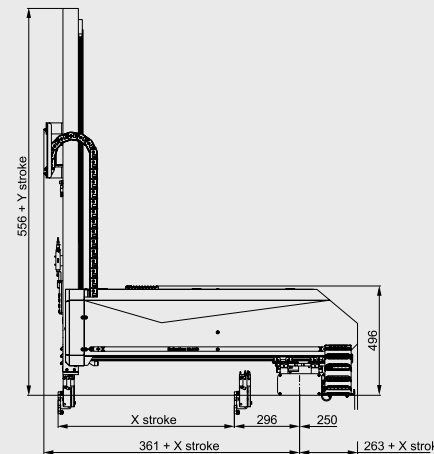

Picture: MotionLiner 20.0 XD

OPTIONS

MOTION LINER 5.0 | 10.0 | 20.0 MULTIHEAD

APPLICATION

- several parallel applications
- connected moulding machines
- automation processes
- modular system
- extremely rigid design



MOTION LINER 5.0 | 10.0 | 20.0 DUAL-Y

APPLICATION

- several parallel applications for 3 plate tools
- modular system
- extremely rigid design

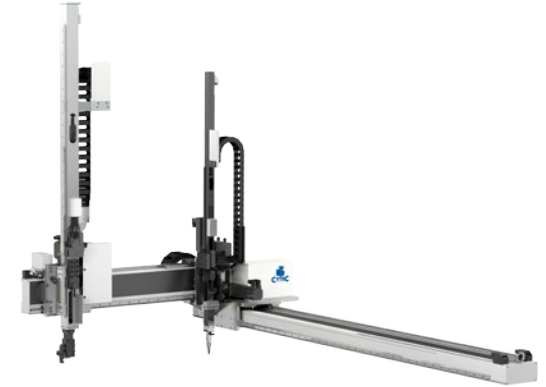

MOTION LINER 5.0 | 10.0 | 20.0 180°

APPLICATION

- wide operation range
- high dynamic 180° rotation
- modular system
- extremely rigid design

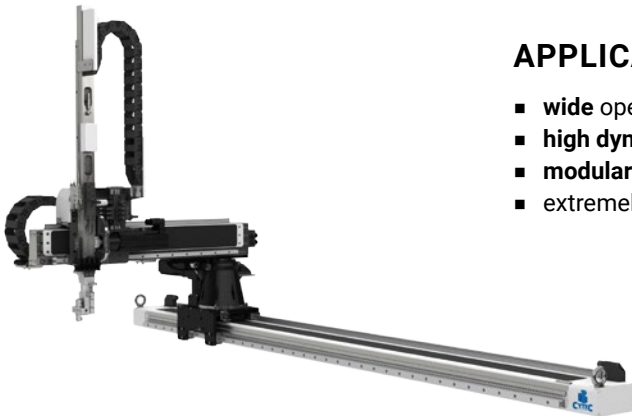

MOTION LINER 5.0 | 10.0 | 20.0 360°

APPLICATION

- wide operation range
- high dynamic 360° rotation
- modular system
- extremely rigid design

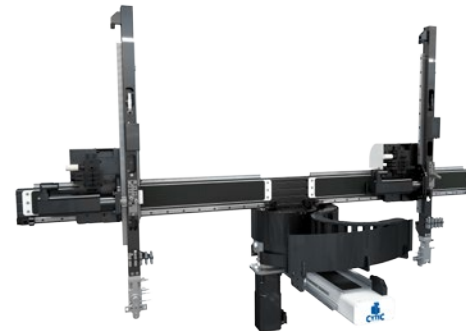



THE CYTEC WARRANTY

5-year-warranty on all Motion Pickers and Motion Liners*.

As the link between the machine and the workpiece, handling devices have an enormous influence on process accuracy and efficiency. Their stability and precision are the basis for reliability and utilization rate of the injection molding machine and machine tools.

The Motion Pickers and Motion Liners convince through **reliability and highest quality**. Our Standards are constantly rising. - With the 5-year manufacturer's warranty, CYTEC has this virtue made a company promise.

- ✓ Low holding time
- ✓ High precision
- ✓ 5-year-warranty



CONTACT

CyTec Systems UK Ltd.

Unit H - 100 Shaw Road (Off Daltry Street)
Oldham, OL1 4AB
United Kingdom

CONTACT US!

We advise you personally.



E-MAIL
sales@cytec-uk.com



SERVICE-HOTLINE
+44 (0) 161 / 678 70 90

* Applies to new equipment sold for the first time after 01.01.2020 and with annual maintenance of new equipment by our service experts.